

Delivery Instructions

KNO Publishers Distribution

1. Delivery addresses

Koch, Neff & Oetinger
Verlagsauslieferung GmbH
Wareneingang/Incoming Goods

Administration: Eric Schlueter
Assistant: Wolfgang Gerber

D-70565 Stuttgart-Vaihingen
Industriegebiet/Industrial Estate
Am Wallgraben 110

Contact Incoming Goods:
Martin Schulz
Tel.: +49 711 7899-1611
Fax: +49 711 7899-1618
E-Mail: wareneingang@kno-va.de

2. KNO VA-External Storage Facility

Personal Contact Incoming Goods:
Heike Saier/Barbara Schmidbauer

D-72221 Haiterbach
Industriegebiet /Industrial Estate
Metnitzer Straße 50

Tel.: +49 7456 6004
Fax: +49 7456 6003

**Delivery only after prior notification
of warehouse in
D-70565 Stuttgart-Vaihingen**

3. Delivery hours in Stuttgart and Haiterbach

Monday - Thursday:
7:30 am - 12:00 am and 1:00 - 4:00 pm
Friday
07:30 am - 2:00 pm

In exceptional cases, unloading outside of the
above mentioned opening hours is possible
(work days until 5:00 pm, Fridays until 4:00
pm) and must be coordinated with the Incoming
Goods Department.

4. Notification of arrival of delivery

We reserve the right to choose the place of delivery, depending on demand. Place of delivery is either Stuttgart or the external storage facility at Haiterbach. Delivery of pallets must therefore be announced with one day's notice.

In order to avoid delivery jams and long waiting times, periods must be appointed with our Incoming Goods Department in order to assure synchronized delivery slots. Unannounced or late delivery will be allocated to the next free delivery slot. We reserve the right to divert unannounced delivery to our external storage facility at the sender's expense.

Delivery must be made at least 48 hours ahead of the target time (to be coordinated with the customer/publisher). Announcement of delivery times:

Tel.: +49 711 7899-1611

Fax: +49 711 7899-1618

E-Mail: wareneingang@kno-va.de

KNO VA will charge a fee of 100 EUR for unannounced deliveries.

5. Delivery Note

Each consignment must be accompanied with a delivery note apart from the usual freight papers, which must carry the following information:

- Exact delivery address (cf. Page 1)
- Supplier & date of delivery
- Publisher
- Exact title & short title & ISBN/EAN
- Edition number
- Total number per title/article
- Number of pallets per title/article
- Number of Items per pallet

The Delivery note must be tendered by the haulier to the Incoming Goods Department together with the delivered goods. A fee of 25 EUROS will be charged for missing delivery notes or for missing information on the note.

6. Freight Costs

Delivery is Carriage-Free Stuttgart-Vaihingen or Haiterbach.

7. Customs

All consignments arriving from abroad must be delivered free from Customs & Excise-duties. Subject to prior arrangement with the Incoming Goods Department, customs clearance may be effected by one of our customs agents before delivery.

8. Loading of truck

Goods on Euro-Pool Pallets can only be loaded on ramps with an electric fork lift entering from the truck's rear. Please do not load the pallets transversely. Side loading is not possible. Goods destined for KNO VA must be readily accessible and must not be blocked by extraneous goods. Major obstacles impairing unloading may lead to non-acceptance of goods. The truck must provide sufficient space to accept a bridge plate.

9. Checking Incoming Consignments in the Incoming Goods Department

KNO VA accepts the goods with reservations. The driver is to receive only a receipt confirming the number of packages/items. Checking of quantities and type of items is done later with the help of the delivery note. External damage to the consignment must be confirmed in writing and on the delivery papers to KNO VA by the driver.

10. Exchange of pallets

All consignments must come on **perfect Euro-Pool-Pallets** that are **fit for exchange**. These are returned by the Incoming Goods Department **with used pallets which are fit for exchange**. If there are no sufficient stocks available for exchange, return of pallets or clearing will be done in due course. In this case the driver will receive a pallet slip confirming the difference in quantity. A return of pallets is only possible on presentation of the original pallet slip.

11. Packaging

- All goods must be delivered on Euro-Pool-Pallets (1200 x 800 mm).
- The pallets must be packed to a maximum height of 1,100 mm including the pallet and the top cover.
- Only one title is permitted per pallet.
- Layers of goods must be stacked on one another in a staggered fashion [refer to Illustration]. Each stacking layer must contain an equal number of books. Layers must be separated from one another by cardboard to prevent slipping. (3 to 5 pieces per pallet).
- Packaged goods must not exceed at any point the clearance of the pallet: blocks of books must have a minimum distance from the outer edges of the pallet of at least 3 cm (approx. 1 1/2 inch).

- The books must be protected on the pallet surface and at the top by a layer of gray cardboard.
- The pallet must be secured with a robust cover and strapping tape and the sides must be protected with stretch-film wrapping and edge protection.
- Both the pallet and the blocks of books must be protected by stretch film to prevent slipping of goods.
- The pallets must be stackable.
- The following information must be provided on the narrow side of every pallet in a clearly visible manner: the publisher, the number of the title, the short title, the edition, the quantity.
- Each packaging unit must be marked with clearly visible and legible writing detailing: the publisher, the EAN, the short title, the quantity.
- Packaging units must always contain the same number of titles.
- Only materials as detailed in section 13 of this delivery advice may be deployed.

The work involved for repackaging a pallet e.g. because of exceeding the maximum height or due to faulty packaging will be billed with 30 EUROS per pallet.

Illustration: **Delivery of a packaged pallet**

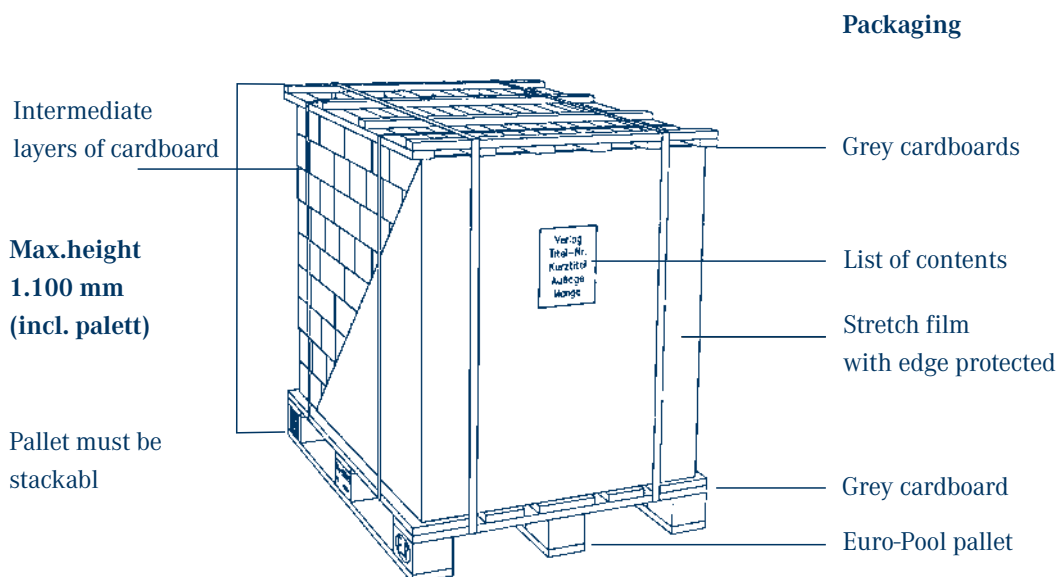

12. Delivery of small quantities on mixed pallets

The delivery on mixed pallets is exclusively intended for the delivery of small quantities. Greater quantities must always be on dedicated pallets.

- Apart from the delivery note, a further requirement for mixed pallets is the list of contents which must be fitted on the narrow face of the pallet detailing quantities and EAN/title numbers.
- Different titles must be clearly separated from one another and must be stacked with flush faces.
- One title must not be split up amongst several pallets.
- Each packaging unit must be marked with clearly visible and legible writing detailing: the publisher, the EAN, the short title, the quantity.
- If small quantities are forwarded via packing services, the packages must bear the information „Incoming Goods Department“ together with the publisher’s name.
- Individual packages must not exceed a total weight of 18 kg.

13. Delivery of Units of Sale

One unit of sale (SU) counts as one item and must be marked as such.

Multi-volume editions under one EAN are a one unit of sale and must be packaged as one set (using banderoles or shrink wrapping or boxes) and labeled accordingly when delivered.

14. Delivery of Packaging Material

The following packing materials may be used:

Pallets: Only Euro-Pool Pallets

- Covers: Made of solid wood (no particle board and sturdy corrugated cardboard), no plastic material, no Euro-pallets, nor one-way pallets.
- Tightening straps: Only PP-plastic tape, no metal tape
- Wrapping film: Only transparent PE-film (no-dye)
- Carton which can be recycled
- Stuffing Material: Only corrugated cardboard and paper, no styrene, no plastic waste material, no pop-corn chips. no bio-packs or similar

15. Delivery of food stuffs and hazardous products

Due to confined storage space and because of statutory limitations, the delivery of foods stuff and hazardous products must be coordinated with the head of the Incoming Goods Department or the management of the Freight Department. Coordination must be at least one week ahead of delivery. In some cases, a destination not mentioned in these Delivery Instructions may be specified.

16. Non-compliance with these Delivery Instructions

We reserve the right to charge extra time for Incidents of non-compliance to the customer/publisher.

Please refer to the Check List attached.

Thank you very much in advance for complying with these Instructions!

Valid as of 11/2011